



PRODUCT INFORMATION

January 2018



KPN349WEK

Ravaglioli 4.2t Electro-Mechanical Clear Floor Hoist

The Ravaglioli KPN349WEK 4.2T electro-mechanical clear floor hoist is a screw type hoist with an automatic and permanent nut lubrication system to guarantee efficient lubrication during lifting and descent.

Manufactured by Ravaglioli in Italy, the main nut is made of bronze (no plastic component) with high resistance to wear for greater safety and the steel high resistance rolled screw provides a long working life.

The KPN349WEK tubular structure has been achieved with 5 robot welded sections ensuring absolute strength and reliability. Electro-mechanical synchronisation keeps the carriages within an alignment of 20mm and therefore this design guarantees a long service life, minimal maintenance and maximum workplace safety.

Three-stage short arms and two-stage long arms provide asymmetric lifting and feature automatic locking during lifting and automatic unlocking when the arms reach the floor utilising a self-locking conical design. Furthermore, the asymmetric arms facilitate easy and quick access to the inside of the car and are suitable for quick drop-in extensions.

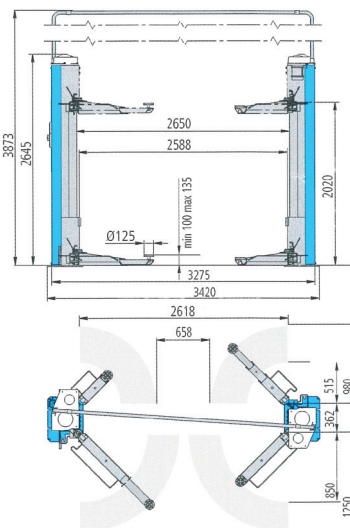

PRODUCT SPECIFICATIONS, FEATURES AND BENEFITS

Lifting capacity of up to 4.2t

Superior lifting height of 2020mm

3-stage short arms and 2-stage long arms

Permanent nut lubrication system - high resistance to wear

Steel rolled screw designed for a long service life

Electro-mechanical synchronisation of carriages

Synchronised alignment within 20mm

Automatic locking and unlocking

Easy and quick access to a vehicle interior

Width between columns of 2650mm

Column height of 2645mm

Overall hoist height of 3873mm

Overall hoist width of 3420mm

ORDERING INFORMATION

KPN349WEK 4.2t Electro-Mechanical Clear Floor Hoist



4 Year Warranty when installed & serviced by Alemlube